

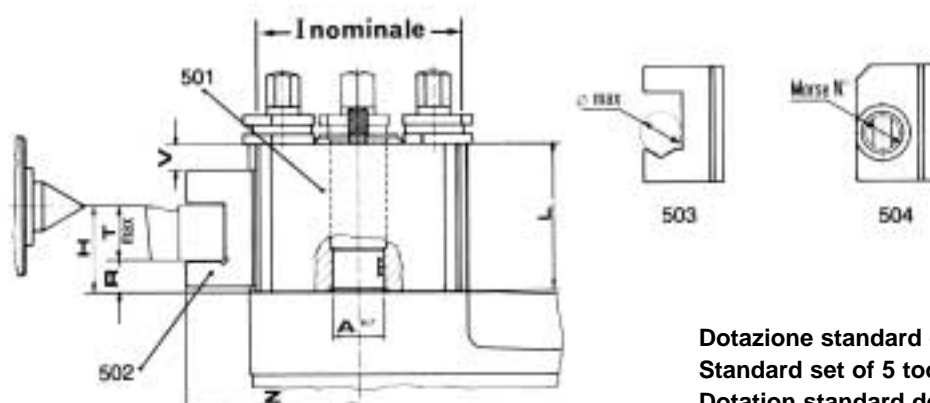

- Accessori per torni paralleli convenzionali
- Accessories for conventional centre lathes
- Accessoires pour tours parallèles conventionnels
- Zubehör für konventionelle parallele Drehmaschinen

Torretta portautensili statica a cambio rapido
Quick change toolpost
Tourelle porte-outils à changement rapide
Schnellwechsel-Revolverkopf



Dotazione standard di 5 portautensili
Standard set of 5 toolholders
Dotation standard de 5 porte-outils
Standardausstattung von 5 Werkzeughaltern

Codice N° Code N° Code N° Bestell N°	Dimensioni - Dimensions - Dimensions - Maße									
	I mm	H7 A mm	Min H mm	Max H mm	L mm	R mm	Max T mm	Z mm	Max Ø mm	Morse N°
501/5/MK-00	40,0	11	15,5	22,5	32	5,5	10	40	10	-
501/5/O-MR	48,2	15	21	29	38	7	14	49	11	1
501/5/M	57,7	18	24	34	45	8	16	56	14	1
501/5/AR-AP	64,5	18	25	41	56	9	16	63	16	1
501/5/A	82,0	24	32	42	60	12	20	75	18	2
501/5/BR-BP	91,6	28	38	53	75	13	25	90	20	3
501/5/B	100,0	30	47	61	85	15	32	100	24	3
501/5/C	115,3	38	51	72	94	19	32	108	26	4
501/5/D	130,0	42	61	95	120	21	40	137	36	4
501/5/E	168,9	52	75	111	142	25	50	162	38	5
501/5/F-EE	168,9	57	86	124	154	26	60	177	40	5

Dotazione standard – Standard set – Dotation standard - Standardausstattung		
Codice N° Code N° Code N° Bestell N°	Articolo – Article – Article – Artikel	N° pezzi N° pieces N° pieces N° Stücke
501	torretta con bloccaggi – toolpost with clampings tourelle avec serrages – Schnellwechsel-Revolverkopf mit Klemmungen	1
502	portautensile con sede piana + viti e regolazione toolholder for tool bits + screws and adjustment porte-outil pour outils carrés et méplats + vis et réglage Werkzeughalter für Flachstähle + Schrauben und Verstellung	3
503	portautensile con sede prismatica + viti e regolazione toolholder for round shanks + screws and adjustment porte-outil pour outils ronds + vis et réglage Werkzeughalter mit prismatischer Führung + Schrauben und Verstellung	1
504*	portautensile con sede conica + viti e regolazione toolholder for Morse taper shank + screws and adjustment porte-outil pour outils cône Morse + vis et réglage Werkzeughalter mit Morsekegel + Schrauben und Verstellung	1
515	chiave a T – square socket wrench clé a douille carrée – Vierkantsteckschlüssel	1
516	chiave a pipa - hexagonal socket wrench clé a douille hexagonale – Sechskantsteckschlüssel	1

* Per la torretta MK-00 è sostituito dal codice 502
For MK-00 toolpost is replaced by code 502
Pour la tourelle MK-00 est remplacé par code 502
Für MK-00 Revolverkopf wird mit Code 502 ersetzt



Dotazione standard di 6 portautensili
Standard set of 6 toolholders
Dotation standard de 6 porte-outils
Standardausstattung von 6 Werkzeughaltern

Codice N° Code N° Code N° Bestell N°	Dimensioni - Dimensions - Dimensions - Maße										
	I mm	H7 A mm	Min H mm	Max H mm	L mm	R mm	Max T mm	Z mm	Max Ø mm	Morse N°	
501/6/MK-00	40,0	11	15,5	22,5	32	5,5	10	40	10	-	
501/6/O-MR	48,2	15	21	29	38	7	14	49	11	1	
501/6/M	57,7	18	24	34	45	8	16	56	14	1	
501/6/AR-AP	64,5	18	25	41	56	9	16	63	16	1	
501/6/A	82,0	24	32	42	60	12	20	75	18	2	
501/6/BR-BP	91,6	28	38	53	75	13	25	90	20	3	
501/6/B	100,0	30	47	61	85	15	32	100	24	3	
501/6/C	115,3	38	51	72	94	19	32	108	26	4	
501/6/D	130,0	42	61	95	120	21	40	137	36	4	
501/6/E	168,9	52	75	111	142	25	50	162	38	5	
501/6/F-EE	168,9	57	86	124	154	26	60	177	40	5	

Dotazione standard – Standard set – Dotation standard - Standardausstattung		
Codice N° Code N° Code N° Bestell N°	Articolo – Article – Article – Artikel	N° pezzi N°pieces N°pieces N° Stücke
501	torretta con bloccaggi toolpost with clampings tourelle avec serrages Schnellwechsel-Revolverkopf mit Klemmungen	1
502	portautensile con sede piana + viti e regolazione toolholder for tool bits + screws and adjustment porte-outil pour outils carrés et méplats + vis et réglage Werkzeughalter für Flachstähle + Schrauben und Verstellung	4
503	portautensile con sede prismatica + viti e regolazione toolholder for round shanks + screws and adjustment porte-outil pour outils ronds + vis et réglage Werkzeughalter mit prismatischer Führung + Schrauben und Verstellung	1
504*	portautensile con sede conica + viti e regolazione toolholder for Morse taper shank + screws and adjustment porte-outil pour outils cône Morse + vis et réglage Werkzeughalter mit Morsekegel + Schrauben und Verstellung	1
515	chiave a T square socket wrench clé a douille carrée Vierkantsteckschlüssel	1
516	chiave a pipa hexagonal socket wrench clé a douille hexagonale Sechskantsteckschlüssel	1

* Per la torretta MK-00 è sostituito dal codice 502
 For MK-00 toolpost is replaced by code 502
 Pour la tourelle MK-00 est remplacé par code 502
 Für MK-00 Revolverkopf wird mit Code 502 ersetzt

Accessori per torni paralleli convenzionali
 Accessories for conventional centre lathes
 Accessoires pour tours parallèles conventionnels
 Zubehör für konventionelle parallele Drehmaschinen

Componenti per torretta statica
 Quick change toolpost spare parts
 Pièces de rechange pour tourelle à changement rapide
 Ersatzteile für Schnellwechsel-Revolverkopf

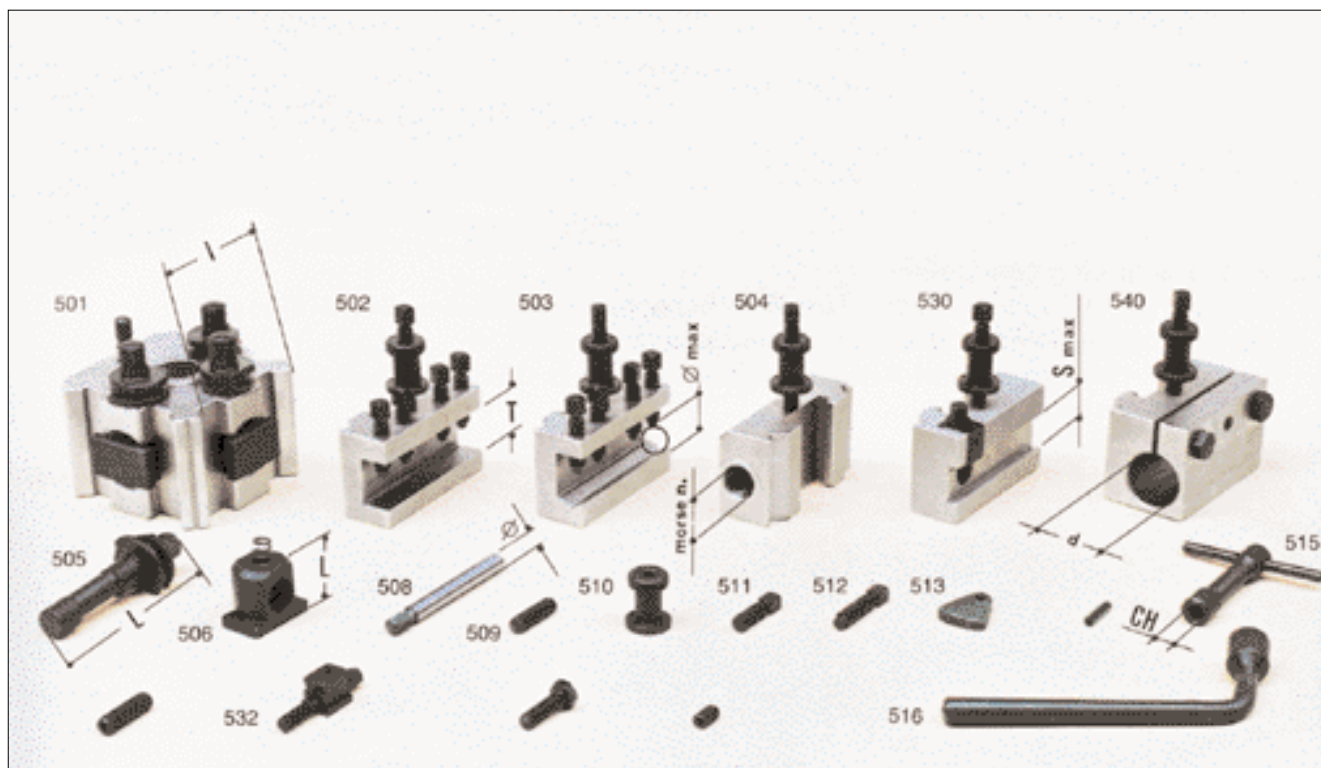

Codice N° Code N° Code N° Bestell N°	Articolo Article Article Artikel	Dimensioni - Dimensions - Dimensions - Maße												
			MK 00	O.MR	M	AR AP	A	BR BP	B	C	D	E	F.EE	
501	corpo body corps Körper	l mm	40,0	48,2	57,7	64,5	82,0	91,6	100,0	115,3	130,0	168,9	168,9	
502	portautensile con sede piana toolholder for tool bits porte-outil pour outils carrés Werkzeughalter für Flachstähle	T max mm	10	14	16	16	20	25	32	32	40	50	60	
503	portautensile con sede prismatica toolholder for round shanks porte-outil pour outils ronds Wkz.halter mit prismatischer Führung	Ø max mm	10	11	14	16	18	20	24	26	36	38	40	
504	portautensile con sede conica toolholder for Morse taper shank porte-outil pour outils cône Morse Werkzeughalter mit Morsekegel	Morse N°	-	1	1	1	2	3	3	4	4	5	5	

Codice N° Code N° Code N° Bestell N°	Articolo Article Article Artikel	Dimensioni - Dimensions - Dimensions - Maße												
			MK 00	O.MR	M	AR AP	A	BR BP	B	C	D	E	F.EE	
505	eccentrico eccentric clamp bolt boulon excentrique Exzenterbolzen	L mm	47	54	67	80	90	108	123	141	170	200	215	
506	tirante con molle draw-in block with springs pièce de blocage Spannstück mit Feder	L mm	16	20	20	26	31	37	42	47	56	67	67	
508	spina riferimento dowel pin broche de positionnement Passtift	Ø mm	6	7	7	8	10	10	12	14	14	16	16	
509	prigioniero stud prisonnier Stiftschraube	filetto thread filet Gewinde	M6	1/4"	5/16"	5/16"	3/8"	3/8"	7/16"	1/2"	9/16"	5/8"	5/8"	
510	rocchetto di regolazione height adjustment sleeve manchon réglage hauteur Verstellbuchse	filetto thread filet Gewinde	M6	1/4"	5/16"	5/16"	3/8"	3/8"	7/16"	1/2"	9/16"	5/8"	5/8"	
511	vite bloccaggio rocchetto sleeve lock screw vis blocage manchon Buchsenklemmschraube	filetto thread filet Gewinde	M6	1/4"	5/16"	5/16"	3/8"	3/8"	7/16"	1/2"	9/16"	5/8"	5/8"	
512	vite bloccaggio utensile tool lock screw vis blocage outil Werkzeughalter flemmschraube	filetto thread filet Gewinde	M6	1/4"	5/16"	5/16"	3/8"	3/8"	7/16"	1/2"	9/16"	5/8"	5/8"	
513	estrattore ejector chasse cône Austreiber	spessore thickness épaisseur Dicke mm	-	-	5	5	7	9	9	12	17	16	16	
515	chiave a T square socket wrench clé à douille carrée Vierkantsteckschlüssel	CH mm	5	6	7	7	9	9	10	12	14	16	16	
516	chiave a pipa hexagonal socket wrench clé à douille hexagonale Sechskantsteckschlüssel	CH mm	8	8	10	12	14	17	17	21	21	27	27	
530	portautensile per lama da taglio toolholder for parting blades porte-outil pour outils à tronçonner Werkzeughalter für Abstechstähle	S max mm	-	-	15X4	18X4	20X6	20X6	25X6	30X6	35X8	40X10	40X10	
532	nasello con vite e spina clamping block with screw and pin bloc de serrage avec vis et goujon Klemmstück mit Schraube und Stift	filetto thread filet Gewinde	-	-	5/16"	5/16"	3/8"	3/8"	7/16"	1/2"	9/16"	5/8"	5/8"	
540	portautensile per baren toolholder for boring bars porte-outil pour outils à aléser Werkzeughalter für Bohrstangen	d mm	-	14	18	20	25	40	40	50	60	60	60	

N.B.: Sull'ordine indicare codice dell'articolo e tipo di torretta Es.: portautensile 503/M
When ordering, please give article code and toolpost type Ex.: toolholder 503/M
À la commande spécifier code de l'article et type de la tourelle Ex.: porte-outil 503/M
Im Bestellfalle Artikel Code und Revolverkopf Typ angeben z.B.: Werkzeughalter 503/M

Accessori per torni paralleli convenzionali
Accessories for conventional centre lathes
Accessoires pour tours parallèles conventionnels
Zubehör für konventionelle parallele Drehmaschinen

Torretta portautensili girevole a cambio rapido TGA-R a 24 posizioni con adduzione refrigerante
 Quick change indexing toolpost TGA-R with 24 positions on crown gears and refrigerating conduction
 Tourelle porte-outils indexable TGA-R à changement rapide avec 24 positions sur couronnes dentées et adduction réfrigérante
 Indexierter Schnellwechsel-Revolverkopf TGA-R mit 24 Stellungen auf Zahnkränze und erfrischender Adduktion

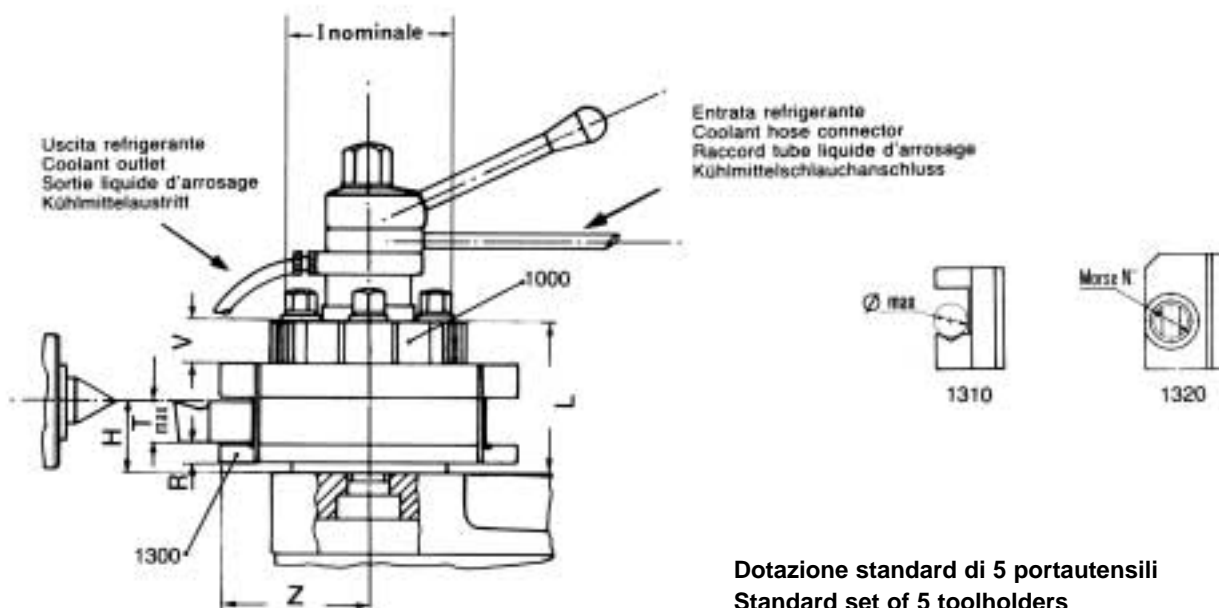

Dotazione standard di 5 portautensili
 Standard set of 5 toolholders
 Dotation standard de 5 porte-outils
 Standardausstattung von 5 Werkzeughaltern

Codice N° Code N° Code N° Bestell N°	Dimensioni - Dimensions - Dimensions - Maße												
	Max H mm	Max T mm	R mm	V mm	I mm	L mm	Z mm	Max Ø mm					
1000/5/TGA-R-150	33	20	12	26	64,5	76	73	18					
1000/5/TGA-R-200	38	25	12	29	82	89	86	20					
1000/5/TGA-R-250	38	25	12	40	91,6	100	94	20					
1000/5/TGA-R-300	48	32	15	39,5	100	106	103	24					
1000/5/TGA-R-350	52	32	19	45	115,3	118	115	26					
1000/5/TGA-R-400	62	40	21	50	130	135	137	36					

Dotazione standard – Standard set – Dotation standard - Standardausstattung		
Codice N° Code N° Code N° Bestell N°	Articolo – Article – Article – Artikel	N° pezzi N° pieces N° pieces N° Stücke
1000	torretta girevole con bloccaggi indexing toolpost with clampings tourelle indexable avec serrages indexierter Revolverkopf mit Klemmungen	1
1300	portautensile con sede piana + viti e regolazione toolholder for tool bits + screws and adjustment porte-outil pour outils carrés et méplats + vis et réglage Werkzeughalter für Flachstähle + Schrauben und Verstellung	4
1310	portautensile con sede prismatica + viti e regolazione toolholder for round shanks + screws and adjustment porte-outil pour outils ronds + vis et réglage Werkzeughalter mit prismatischer Führung + Schrauben und Verstellung	1
515	chiave a T – square socket wrench clé a douille carrée – Vierkantsteckschlüssel	1
516	chiave a pipa - hexagonal socket wrench clé a douille hexagonale – Sechskantsteckschlüssel	1



Dotazione standard di 6 portautensili
Standard set of 6 toolholders
Dotation standard de 6 porte-outils
Standardausstattung von 6 Werkzeughaltern

Codice N° Code N° Code N° Bestell N°	Dimensioni - Dimensions - Dimensions - Maße															
	Min H mm	Max T mm	R mm	V mm	I mm	L mm	Z mm	Max Ø mm	Morse N°							
1000/6/TGA-R-150	33	20	12	26	64,5	76	73	18	2							
1000/6/TGA-R-200	38	25	12	29	82	89	86	20	3							
1000/6/TGA-R-250	38	25	12	40	91,6	100	94	20	3							
1000/6/TGA-R-300	48	32	15	39,5	100	106	103	24	4							
1000/6/TGA-R-350	52	32	19	45	115,3	118	115	26	4							
1000/6/TGA-R-400	62	40	21	50	130	135	137	36	5							

Dotazione standard – Standard set – Dotation standard - Standardausstattung		
Codice N° Code N° Code N° Bestell N°	Articolo – Article – Article – Artikel	N° pezzi N° pieces N° pieces N° Stücke
1000	torretta girevole con bloccaggi indexing toolpost with clampings torelle indexable avec serrages indexierter Revolverkopf mit Klemmungen	1
1300	portautensile con sede piana + viti e regolazione toolholder for tool bits + screws and adjustment porte-outil pour outils carrés et méplats + vis et réglage Werkzeughalter für Flachstähle + Schrauben und Verstellung	4
1310	portautensile con sede prismatica + viti e regolazione toolholder for round shanks + screws and adjustment porte-outil pour outils ronds + vis et réglage Werkzeughalter mit prismatischer Führung + Schrauben und Verstellung	1
1320	portautensile con sede conica (Morse) + viti e regolazione toolholder for Morse taper shank + screws and adjustment porte-outil pour outils cône Morse + vis et réglage Werkzeughalter mit Morsekegel + Schrauben und Verstellung	1
515	chiave a T square socket wrench clé a douille carrée Vierkantsteckschlüssel	1
516	chiave a pipa hexagonal socket wrench clé a douille hexagonale Sechskantsteckschlüssel	1

Componenti per torretta girevole TGA-R
 Indexing toolpost TGA-R spare parts
 Pièces de rechange pour tourelle indexable TGA-R
 Ersatzteile für Indexierten Revolverkopf TGA-R

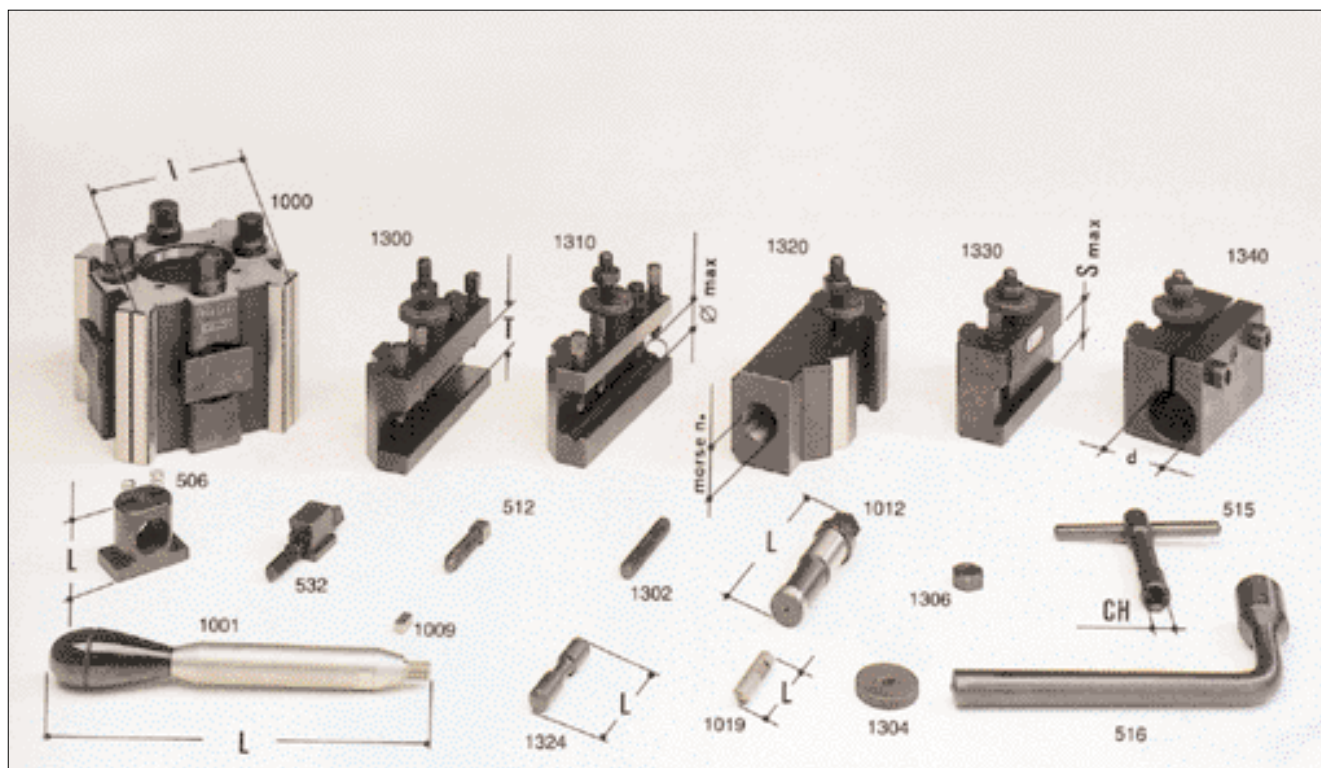

Codice N° Code N° Code N° Bestell N°	Articolo Article Article Artikel	Dimensioni - Dimensions - Dimensions - Maße						
			TGA 150R	TGA 200R	TGA 250R	TGA 300R	TGA 350R	TGA 400R
1000	corpo body corps Körper	I mm	64,5	82	91,6	100,0	115,3	130,0
1001	leva lever levier Hebel	L mm	105	147	182	197	217	242
1009	perno pin pivot Zapfen	L mm	12	13,5	14	16	18	18
1012	eccentrico eccentric clamp bolt boulon excentrique Exzenterbolzen	L mm	71	81	97	100	110	121
1019	perno pin pivot Zapfen	L mm	29	35,5	41,5	46	46	46
1300	portautensile con sede piana toolholder for tool bits porte-outil pour outils carrés Werkzeughalter für Flachstähle	T _{Max} mm	20	25	25	32	32	40
1302	prigioniero stud prisonnier Stiftschraube	filetto thread filet Gewinde	3/8"	3/8"	3/8"	7/16"	1/2"	9/16"

Codice N° Code N° Code N° Bestell N°	Articolo Article Article Artikel	Dimensioni - Dimensions - Dimensions - Maße						
			TGA 150R	TGA 200R	TGA 250R	TGA 300R	TGA 350R	TGA 400R
1304	rocchetto di regolazione height adjustment sleeve manchon réglage hauteur Verstellbuchse	filetto thread filet Gewinde	3/8"	3/8"	3/8"	7/16"	1/2"	9/16"
1306	vite bloccaggio rocchetto sleeve lock screw vis blocage manchon Buchsenklemmschraube	filetto thread filet Gewinde	3/8"	3/8"	3/8"	7/16"	1/2"	9/16"
1310	portautensile con sede prismatica toolholder for round shanks porte-outil pour outils ronds Werkzeughalter mit prismatischer Führung	Ø _{Max} mm	18	20	20	24	26	36
1320	portautensile con sede conica toolholder for Morse taper shank porte-outil pour outils cône Morse Werkzeughalter mit Morsekegel	Morse N°	2	3	3	4	4	5
1324	estrattore – ejector chasse cône – Austreiber	L mm	50	58	72	70	80	110
1330	portautensile per lama da taglio toolholder for parting blades porte-outil pour outils à tronçonner Werkzeughalter für Abstechstähe	S _{Max} mm	20X6	20X6	20X6	25X6	30X6	35X8
1340	portautensile per baren toolholder for boring bars porte-outil pour outils à aléser Werkzeughalter für Bohrstangen	d mm	20	25	32	40	50	60

COMPONENTI COMUNI CON LE TORRETTE STATICHE
SPARE PARTS IN COMMON WITH QUICK CHANGE TOOLPOSTS
PIÈCES DE RECHANGE EN COMMUN AVEC TOURELLES À CHANGEMENT RAPIDE
ERSATZTEILE ÜBEREINSTIMMEND MIT SCHNELLWECHSEL-REVOLVERKOPFEN

Codice N° Code N° Code N° Bestell N°	Articolo Article Article Artikel	Dimensioni - Dimensions - Dimensions - Maße						
			TGA 150R	TGA 200R	TGA 250R	TGA 300R	TGA 350R	TGA 400R
506	Tirante con molle Draw-in block with springs Pièce de blocage Spannstück mit Feder	L mm	AR AP 26	A 31	BR BP 37	B 42	C 47	D 56
512	vite bloccaggio utensile tool lock screw vis blocage outil Werkzeughalter flemmschraube	filetto thread filet Gewinde	AR AP 5/16"	A 3/8"	BR BP 3/8"	B 7/16"	C 1/2"	D 9/16"
515	chiave a T square socket wrench clé à douille carrée Vierkantsteckschlüssel	CH mm	AR AP 7	A 9	BR BP 9	B 10	C 12	D 14
516	chiave a pipa hexagonal socket wrench clé à douille hexagonale Sechskantsteckschlüssel	CH mm	AR AP 12	A 14	A 14	B 17	B 17	D 21
532	nasello con vite e spina clamping block with screw and pin bloc se serrage avec vis et goujon Klemmstück mit Schraube und Stift	filetto thread filet Gewinde	AR AP 5/16"	A 3/8"	BR BP 3/8"	B 7/16"	C 1/2"	D 9/16"

N.B.: Sull'ordine indicare codice dell'articolo e tipo di torretta Es.: portautensile 1310/TGA 150R
When ordering, please give article code and toolpost type Ex.: toolholder 1310/TGA 150R
À la commande spécifier code de l'article et type de la tourelle Ex.: porte-outil 1310/TGA 150R
Im Bestellfalle Artikel Code und Revolverkopf Typ angeben z.B.: Werkzeughalter 1310/TGA 150R

Accessori per torni paralleli convenzionali
Accessories for conventional centre lathes
Accessoires pour tours parallèles conventionnels
Zubehör für konventionelle parallele Drehmaschinen

Torretta portautensili a cambio rapido tipo multifix
Quick change toolpost type multifix
Tourelle porte-outils à changement rapide type multifix
Schnellwechsel Revolverkopf

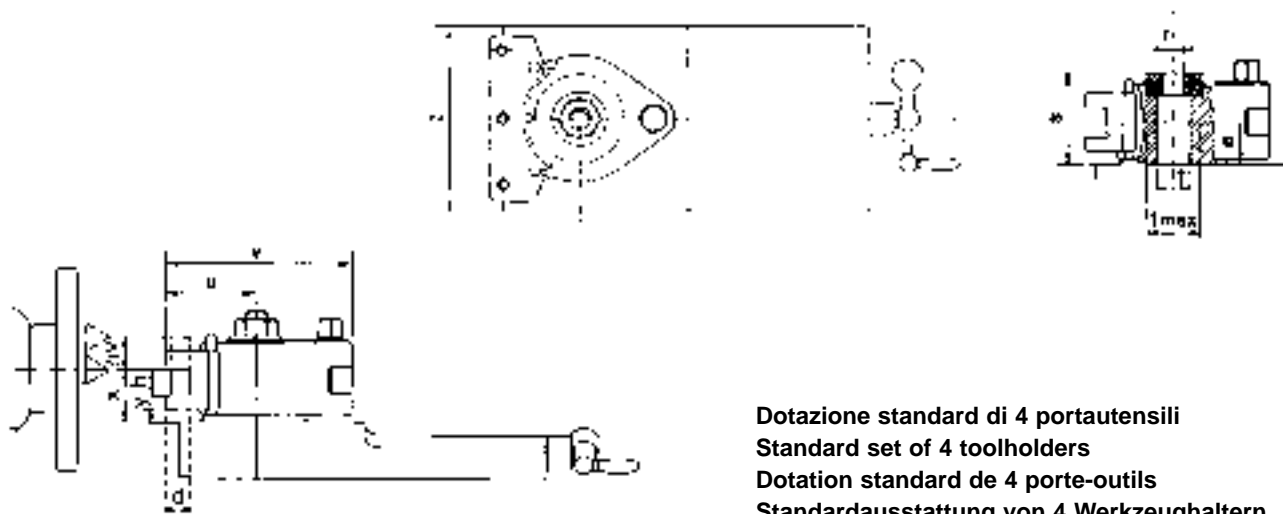

Dotazione standard di 4 portautensili
Standard set of 4 toolholders
Dotation standard de 4 porte-outils
Standardausstattung von 4 Werkzeughaltern

Codice N° Code N° Code N° Bestell N°	Articolo – Article – Article – Artikel	700/4/A	700/4/E	700/4/B	700/4/C	700/4/D1	700/4/D2
700/4	Corpo con dotazione standard: Body standard set: Corps avec dotation standard: Körper mit Standardausstattung:						
	N° 3 Portautensile con sede piana N° 3 Toolholder for tool bits N° 3 Porte-outil pour outils carrés N° 3 Werkzeughalter für Flachstähle	702/A 16X75	702/E 20X100	702/B 25X120	702/C 32X150	702/D1 40X180	702/D2 50X220
	N° 1 Portautensile prismatico N° 1 Toolholder for round shank N° 1 Porte-outil pour outils ronds N° 1 Wkz.halter mit prismatischer Führung	703/A 20X85	703/E 30X100	703/B 30X130	703/C 40X160	703/D1 63X170	703/D2 70X220

TORRETTA A CAMBIO RAPIDO

si adatta a qualsiasi portautensile a cambio rapido standard tedesco
i portautensili possono essere regolati a 40 diverse angolazioni sul corpo centrale
forniti di scala angolazione sul corpo; regolazione altezza portautensile mediante vite a testa zigrinata
Scegliere il corpo portautensili secondo le indicazioni riportate nella tabella

QUICK-CHANGE TOOLHOLDER

fits all standard german quick-change toolholder
toolholders can be adjusted to 40 different angles on the central body
angle scale provided on head; holder height adjustment with a thumb screw
Select tool changer head in accordance with table

TOURELLE A CHANGEMENT RAPIDE

convenable à chaque type de porte-outil à changement rapide allemand
les porte-outils peuvent être réglés à 40 angles différents sur le corps central
échelle des angles sur le corps; réglage hauteur du porte-outil par vis avec tête moletée
Choisir le corps porte-outils selon les indications dans le tableau

SCHNELL-WECHSELHALTER

passend zu allen gängigen deutschen Schnellwechselstahlhaltern
Stahlhalter können in 40 verschiedenen Winkelstellungen am Zentralkörper eingestellt werden
Winkelskala am Kopf; Höhenjustierung der halter über Rändelschraube
Auswahl d. Stahlhalterkopfes nach entsprechender Tabelle

Dimensioni – Dimensions - Dimensions – Maße	A		E		B		C			D1			D2		
	D16	D20	D20	D25	D25	D32	D32	D40	D45	D40	D50	D63	D50	D63	
dimensioni cambiautensile tool changer size dimensions changeur d'outils Wechselhalter Größe															
Potenza max. azionamenti macchina max. machine driver power puissance max. conseillée Antriebsleistung der Maschine ca.	PS	3	6	9	13	19	25								
diam. tornitura macchina machine turning diam. diamètre tournage machine Drehdurchmesser der Maschine	mm	150-300	200-400	300-500	400-700	600-1000	700-1500								
ampiezza max. slitta max. slide width largeur max. du chariot Schlittenbreite max.	z mm	100	120	150	180	200	250								
altezza min. tagliente min. cutting edge height hauteur pointe-chariot min. Schneidkantenhöhe min.	x mm	h+y	h+y	h+y	h+y	h+y	h+y								
altezza max. tagliente max. cutting edge height hauteur pointe-chariot max. Schneidkantenhöhe max.	mm	x+hv	x+hv	x+hv	x+hv	x+hv	x+hv								
regolazione altezza height adjustment réglage hauteur Höhenverstellbarkeit	hv mm	11	17	15	20	11	40	35	30	35	30	20	30	20	
supporto utensile tool support support outil Stahlaufage	y mm	9	10	11	12,5	14	15	16	17	20	21	22	25	25	
ampiezza supporto utensile tool support width épaisseur support outil Auflagenbreite für Arbeitsstahl	d mm	12	20	20	20	30	30	30	35	40	40	45	45	45	
altezza max. utensile max. tool height hauteur max. outil Höhe des Arbeitsstahls max.	h mm	16	20	20	25	25	32	32	40	45	40	50	63	50	63
larghezza max. utensile max. total width encombrement max. Gesamtbreite max.	v mm	100	125	150	192	202	202	230	234	242	275	282	282	282	
altezza totale total height hauteur total Gesamthöhe	s mm	54	68	75	105	122	135								
max. sbalzo max. reach distance max. Ausladung max.	u mm	48	60	71	92	102	102	112	117	124	140	147	147	147	
foro standard standard bore perçage standard Bohrung normal	t mm	20	20	32	40	40	80								
foro max. max. bore perçage max. Bohrung max.	t max mm	31	31	51	70	80	110								
prof. max. foro max. bore depth profondeur max. perçage Tiefe der Ausbohrung max.	e mm	35	35	45	75	75	85								

Componenti per torretta portautensili a cambio rapido
 Quick change toolpost spare parts
 Pièces de rechange pour tourelle à changement rapide
 Ersatzteile für Schnellwechsel-Revolverkopf

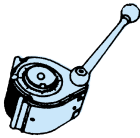
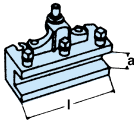
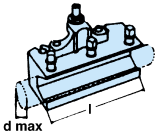
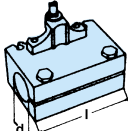
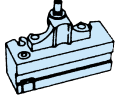

										
corpo portautensili tool changer head corps porte-outils Werkzeughalterkörper	portautensile con sede piana toolholder for tool bits porte-outil pour outils carrés Werkzeughalter für Flachstähle	portautensile prismatico toolholder for round shank porte-outil pour outils ronds Werkzeughalter mit prismatischer Führung	portautensile per baren toolholder for boring bars porte-outil pour outils à aléser Werkzeughalter für Bohrstangen	portautensile per lama da taglio toolholder for parting blades porte-outil pour outils à tronçonner Werkzeughalter für Abstechstähle						
Codice N° Code N° Code N° Bestell N°	Codice N° Code N° Code N° Bestell N°	a mm	l mm	Codice N° Code N° Code N° Bestell N°	d mm	l mm	Codice N° Code N° Code N° Bestell N°	d mm	l mm	Codice N° Code N° Code N° Bestell N°
700/A	702/A 702/A 702/A 702/A	16 16 20 20	75 90 75 90	703/A	20	85	740/A	30	80	730/A
700/E	702/E 702/E	20 25	100 100	703/E	32	100	740/E 740/E	30 40	100 100	730/E
700/B	702/B 702/B 702/B 702/B	25 25 32 32	120 140 120 140	703/B	32	130	740/B	40	120	730/B
700/C	702/C 702/C 702/C 702/C 702/C	32 32 40 40 45	150 170 150 170 170	703/C 703/C	40 50	160 160	740/C 740/C	40 50	160 160	730/C
700/D1	702/D1 702/D1 702/D1	40 50 63	180 180 180	703/D1	63	180	740/D1	63	180	
700/D2	702/D2	50	220	703/D2	70	220	740/D2	63	220	



Apparecchio per torniture di forma sferica
Spherical turning attachment
Appareil pour tournage sphérique
Kugeldrehvorrichtung

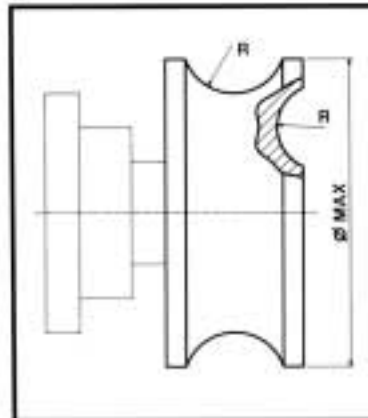
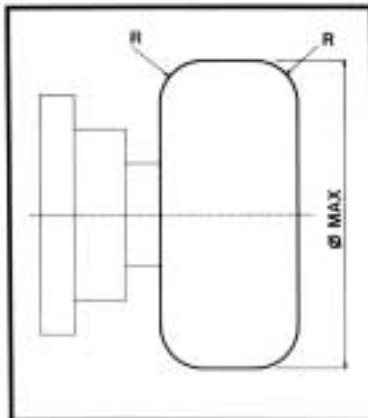
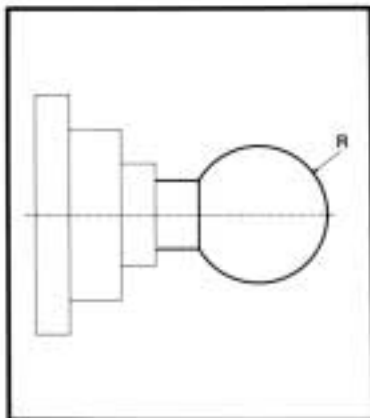
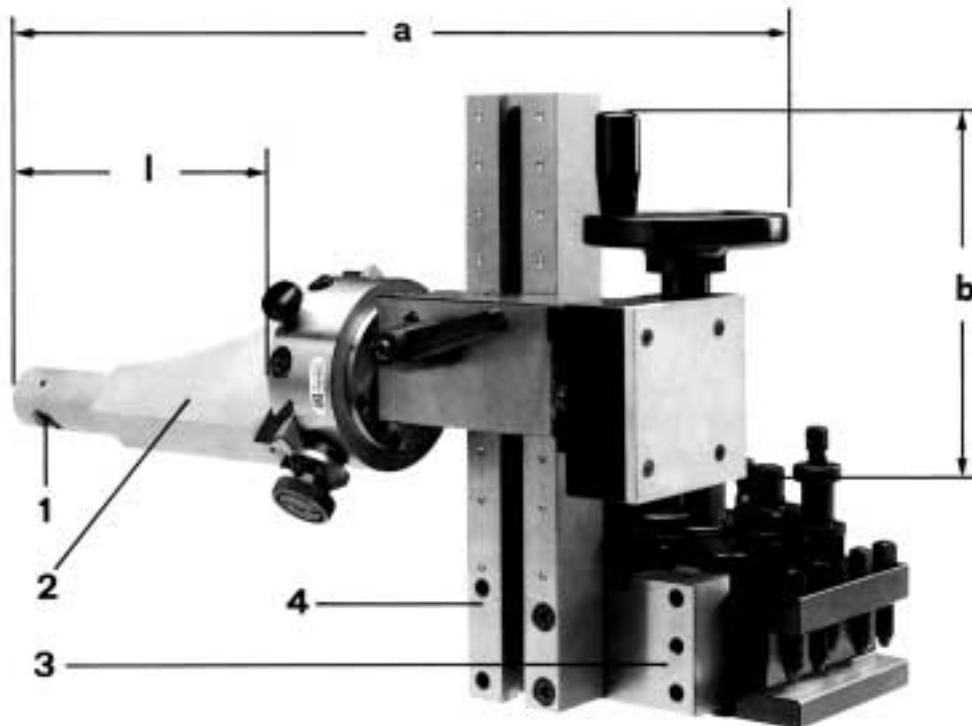

Codice N° Code N° Code N° Bestell N°	Torretta Toolpost Tourelle Revolverkopf	Dimensioni - Dimensions - Dimensions - Maße						R	
		i	l	a	b	Ø _{max}			
600/A	A	82	100/180	265	95	500	0÷100	L'apparecchio è fornito con 2 prolunghe di lunghezza l Attachment is supplied complete with 2 extensions of length l L'appareil est fournit avec 2 prolonges de longueur l Die Drehvorrichtung ist mit 2 Verlängerungen von Länge l geliefert	
600/BR-BP	BR-BP	91,6	100/180	265	95	500	0÷100		
600/B	B	100	100/180	265	95	500	0÷100		
600/C	C	115,3	100/180	265	95	500	0÷100		
600/D	D	130	100/180	265	95	500	0÷100		
600/E	E	168,9	100/180	265	95	500	0÷100		
600/F-EE	F-EE	169,9	100/180	265	95	500	0÷100		

1. Stelo – Toolshank – Queue pour outils – Werkzeugschaft
2. Prolunga – Extension – Prolonge – Verlängerung
3. Adattatore – Adaptor – Adaptateur – Passtück
4. Supporto per la regolazione in funzione del diametro – Support for adjustment as a function of diameter – Support pour réglage en fonction du diamètre – Halter für Verstellung in Funktion von Diameter

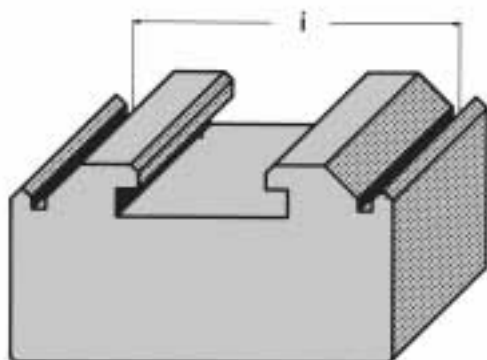

Codice N° Code N° Code N° Bestell N°	Dimensioni Dimensions Maße
	i
613/A	82
613/BR-BP	91,6
613/B	100
613/C	115,3
613/D	130
613/E	168,9
613/F-EE	168,9

Esempi di impiego con apparecchio per torniture sferiche

Esecuzione sagome R10
su flangia \varnothing 400



Esecuzione sagoma sferica di
testa in asse col mandrino



Come figura precedente ma con
apparecchio in posizione rovescita



Esecuzione sagoma concava
di testa in asse col mandrino



Esecuzione gola R50
su albero generico



Esecuzione R200
su esterno flangia \varnothing 200.
(La lavorazione è resa possibile
tramite prolunga speciale)